

# CZ0264



## 描述:

防爆LED(应急)标志灯壳体由玻璃纤维增强聚酯压模成型,透明罩采用抗紫外线PC注塑制成,其稳定性及机械强度高,对工厂或海洋平台中多种化学物质具有良好的防护能力。壳体与透明罩间设有防护密封圈,通过连锁机构使其压紧。选配行程开关,具有连锁开盖断电功能。

## Descriptions:

Explosion-proof LED (emergency) marking light comprises enclosure manufactured in glass fibre reinforced polyester and transparent cover manufactured in polycarbonate. It has good protection to various chemicals in plant or offshore platform as its stability and high mechanical strength. IP seal between enclosure and transparent cover is compacted by interlocking device. The distance switch which is optional can cut the power off automatically when transparent cover is opened.

- 防爆LED标志灯
- 防爆LED应急标志灯, 应急照明时间160min
- 应急型设有故障信号指示、充电信号指示、放电信号指示
- 应急型式分为持续型和非持续型(持续型应急灯具光源在主电源和应急电源工作时均处于点亮状态的应急灯具;非持续型是指光源在主电源工作时不点亮,仅在应急电源工作时才点亮。)
- 有16种标识牌图案供选择,可按用户要求定制。
- IECEx 国际认证, ATEX 欧洲认证

- Explosion-proof LED marking light.
- Explosion-proof LED emergency marking light, emergency time 160min.
- Emergency type has indicator for fault, charging and discharge.
- Emergency types have maintained and non-maintained type. Maintained type can work when either normal power on or emergency power on. Non-maintained type can only work when emergency power on.
- 16 labels for options, others are also available on request.
- IECEx and ATEX certified.

1 区和 2 区

Zone 1 and zone 2

21 区和 22 区

Zone 21 and zone 22



- 防爆标志灯由高品质的全塑外壳制成，防护等级IP66，适用于户内外等各种适用的环境，本安电路防爆标志：Ex db eb ib mb op is q II C T4 Gb Ex tb II C T80°C Db 可用于 1 区和 2 区；21 区和 22 区  
宽电压 AC100~250V 50/60Hz  
LED光源，电子元件设计使用寿命（50000小时）  
应急灯带有三颗LED指示灯，显示故障状态

- The explosion-proof exit sign light fittings have good quality plastic housings, with degree of protection IP66. They are suitable for indoor or outdoor use. Ex-marking for Ex i circuit:  
Ex db eb ib mb op is q II C T4 Gb Ex tb II C T80°C Db  
Can be used in zone 1&2, zone 21&22  
Wide voltage range: AC100~250V 50/60Hz  
Designed life of LEDs and electronics is 50000hours  
Emergency version has three LED signal lamps inside indicating any fault if there is.

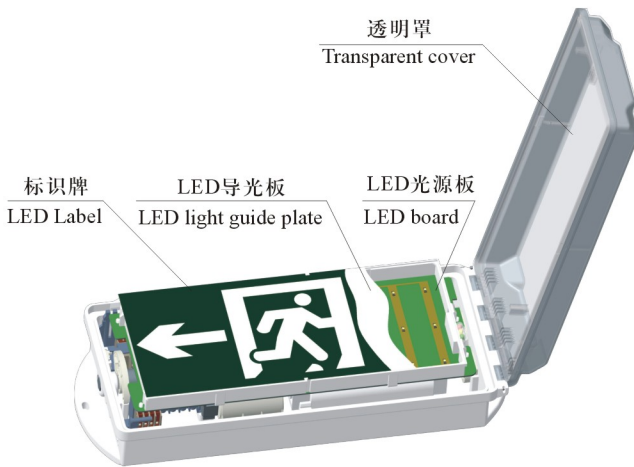

- LED光源前端有导光板，使灯具光源更加柔和。
- 可更换内置式标识牌，在透明罩PC保护下不受外界雨水和粉尘影响，标识牌识别距离可达30米。

- There is light guide plate in front of LEDs to make the light be more soft.
- Built-in pictograms can be replaced, and are visible 30m with PC transparent cover protected from rain and dust.

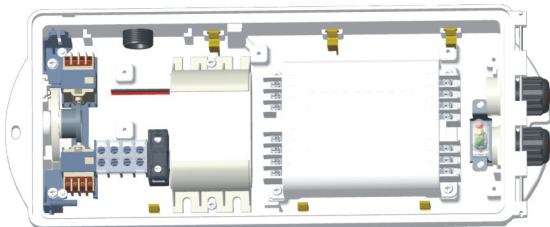

- 可选防爆熔断器和防爆行程开关模块。
- 专用的防爆应急电源模块，具有过压保护、过载保护、恒流输出。
- 电池模块循环充放电次数 ≥ 500次。
- Optional explosion-proof isolation switch and fuse.
- Special explosion-proof emergency power supply modules have the functions of over voltage protection, over load protection and constant current output.
- Circulating charge and discharge of battery module is more than 500times.

**主要数据 Main technical data:**

认证 Certification	防爆标志 Ex mark	符合标准 Meet the standard
<b>IECEX: IECEX CML 16.0135X</b>	Ex eb ib op is q II C T4 Gb Ex tb III C T80°C Db (产品不装熔断器不装行程开关 Product without fuse and without isolation switch)	IEC60079
	Ex db eb ib mb op is q II C T4 Gb Ex tb III C T80°C Db (产品装熔断器装行程开关 Product with fuse and isolation switch)	IEC60079
<b>ATEX: CML 16ATEX3377X</b>	⊕ II 2GD Ex eb ib op is q II C T4 Gb Ex tb III C T80°C Db (产品不装熔断器不装行程开关 Product without fuse and without isolation switch)	EN60079
	⊕ II 2GD Ex db eb ib mb op is q II C T4 Gb Ex tb III C T80°C Db (产品装熔断器装行程开关 Product with fuse and isolation switch)	EN60079

适用范围: 用于 1 区和 2 区; 用于 21 区和 22 区

 使用环境温度:  $-20^{\circ}\text{C} \leq \text{Ta} \leq +55^{\circ}\text{C}$ 

防护等级: IP66

额定电压: AC100 ~ 250V 50/60Hz

功率: 3W

光通量: 160Lm

 接线端子:  $2 \times 2.5\text{mm}^2$ 

标识牌识别距离: 30m

 电缆入口: (标配) 塑制  $1 \times \text{M}25 \times 1.5$ , 电缆外径:  $\Phi 8-17\text{mm}$   
 塑制  $2 \times \text{M}25 \times 1.5$  空塞堵头

符合: CE 2460

重量: 3.20kg

Intended use: Can be used in zone 1 and zone 2

Can be used in zone 21 and zone 22

 Ambient temperature:  $-20^{\circ}\text{C} \leq \text{Ta} \leq +55^{\circ}\text{C}$ 

Degree of protection: IP66

Rated voltage: AC100 ~ 250V 50/60Hz

Power: 3W

Luminous flux: 160Lm

 Terminals:  $2 \times 2.5\text{mm}^2$ 

Recognized distance of label: 30m

Cable entry: (Standard configuration) Moulded plastic

 $1 \times \text{M}25 \times 1.5$ , Outside diameter of cable:  $\Phi 8-17\text{mm}$ 

 Moulded plastic  $2 \times \text{M}25 \times 1.5$  stopping plugs



Conformity to: CE 2460

Weight: 3.20kg

**订购规格 Order specifications:**

描述 Descriptions	订购号 Order No.
产品不装熔断器不装行程开关 Product without fuse and switch fitted	<b>CZ0264/20-LED3W-□-B</b>
产品装熔断器装行程开关 Product with fuse and switch fitted	<b>CZ0264/20-LED3W-□-KF-B</b>

标志编码 (不带不注) Mark code (no matching not noted)

 编码 Code: 80	 编码 Code: 84	 编码 Code: 88	 编码 Code: 92
 编码 Code: 81	 编码 Code: 85	 编码 Code: 89	 编码 Code: 93
 编码 Code: 82	 编码 Code: 86	 编码 Code: 90	 编码 Code: 94
 编码 Code: 83	 编码 Code: 87	 编码 Code: 91	 编码 Code: 95

 电缆引入装置编码详见第 15 页  
 For code of cable gland, see page 15.



**主要数据 Main technical data:**

认证 Certification	防爆标志 Ex mark	符合标准 Meet the standard
<b>IECEX: IECEX CML 16.0135X</b>	Ex eb ib op is q II C T4 Gb Ex tb III C T80°C Db (产品不装熔断器不装行程开关 Product without fuse and without isolation switch)	IEC60079
	Ex db eb ib mb op is q II C T4 Gb Ex tb II C T80°C Db (产品装熔断器装行程开关 Product with fuse and isolation switch)	IEC60079
<b>ATEX: CML 16ATEX3377X</b>	⊕ II 2GD Ex eb ib op is q II C T4 Gb Ex tb III C T80°C Db (产品不装熔断器不装行程开关 Product without fuse and without isolation switch)	EN60079
	⊕ II 2GD Ex db eb ib mb op is q II C T4 Gb Ex tb III C T80°C Db (产品装熔断器装行程开关 Product with fuse and isolation switch)	EN60079

适用范围: 用于 1 区和 2 区; 用于 21 区和 22 区  
 使用环境温度:  $-20^{\circ}\text{C} \leq \text{Ta} \leq +55^{\circ}\text{C}$   
 防护等级: IP66  
 额定电压: AC100 ~ 250V 50/60Hz  
 功率: 3W  
 正常照明和应急照明光通量: 160Lm  
 应急启动时间:  $\leq 0.1\text{S}$   
 应急照明时间: 160min  
 充电时间:  $\geq 24\text{h}$   
 电池配置: CZ0819/1.0Ah 6V  
 电池循环充电次数:  $\geq 500$ 次  
 接线端子:  $2 \times 2.5\text{mm}^2$   
 标识牌识别距离: 30m  
 电缆入口: (标配)塑制  $1 \times \text{M}25 \times 1.5$ , 电缆外径:  $\Phi 8-17\text{mm}$   
                   塑制  $2 \times \text{M}25 \times 1.5$  空塞堵头  
 符合: CE 2460  
 重量: 3.50kg

Intended use: Can be used in zone 1 and zone 2  
                   Can be used in zone 21 and zone 22  
 Ambient temperature:  $-20^{\circ}\text{C} \leq \text{Ta} \leq +55^{\circ}\text{C}$   
 Degree of protection: IP66  
 Rated voltage: AC100 ~ 250V 50/60Hz  
 Power: 3W  
 Luminous flux of normal illumination and emergency: 160Lm  
 Emergency starting time:  $\leq 0.1\text{S}$   
 Emergency illuminating time: 160min  
 Recharging time:  $\geq 24\text{h}$   
 Battery Configuration: CZ0819/1.0Ah 6V  
 Battery designed life:  $\geq 500$  times recharging  
 Terminals:  $2 \times 2.5\text{mm}^2$   
 Recognized distance of label: 30m  
 Cable entry: (Standard configuration) Moulded plastic  
                    $1 \times \text{M}25 \times 1.5$ , Outside diameter of cable:  $\Phi 8-17\text{mm}$   
                   Moulded plastic  $2 \times \text{M}25 \times 1.5$  stopping plugs  
 Conformity to: CE 2460  
 Weight: 3.50kg

**订购规格 Order specifications:**

描述 Descriptions	应急型式 Type of emergency	订购号 Order No.
产品不装熔断器不装行程开关 Product without fuse and switch fitted	持续性 Maintained	<b>CZ0264/20-LED3W-M-□-B</b>
	非持续性 Non maintained	<b>CZ0264/20-LED3W-NM-□-B</b>
产品装熔断器装行程开关 Product with fuse and switch fitted	持续性 Maintained	<b>CZ0264/20-LED3W-M-□-KF-B</b>
	非持续性 Non maintained	<b>CZ0264/20-LED3W-NM-□-KF-B</b>



标志编码 (不带不注) Mark code (no matching not noted)

编码 Code: 80	编码 Code: 84	编码 Code: 88	编码 Code: 92
编码 Code: 81	编码 Code: 85	编码 Code: 89	编码 Code: 93
编码 Code: 82	编码 Code: 86	编码 Code: 90	编码 Code: 94
编码 Code: 83	编码 Code: 87	编码 Code: 91	编码 Code: 95

电缆引入装置编码详见第 15 页  
 For code of cable gland, see page 15.

电缆引入装置编码 Code of cable gland:

编码 Code	规格 Specifications	电缆直径 Cable diameter
<b>B</b>	塑制 1 个 M25 × 1.5 电缆密封套, 塑制 2 个 M25 × 1.5 空塞堵头 One moulded plastic M25 × 1.5 cable gland, two moulded plastic M25 × 1.5 stopping plugs	Φ8-17mm
<b>C</b>	铜制 1 个 CZ0221/M25 × 1.5 金属电缆密封套, 塑制 2 个 M25 × 1.5 空塞堵头 One brass CZ0221/M25 × 1.5 metal cable gland, two moulded plastic M25 × 1.5 stopping plugs	Φ8-17mm
<b>D</b>	塑制 2 个 M25 × 1.5 电缆密封套, 塑制 1 个 M25 × 1.5 空塞堵头 Two moulded plastic M25 × 1.5 cable glands, one moulded plastic M25 × 1.5 stopping plug	Φ8-17mm
<b>E</b>	铜制 2 个 CZ0221/M25 × 1.5 金属电缆密封套, 塑制 1 个 M25 × 1.5 空塞堵头 Two brass CZ0221/M25 × 1.5 metal cable glands, one moulded plastic M25 × 1.5 stopping plug	Φ8-17mm
<b>F</b>	铜制 1 个 CZ0227/M25 × 1.5-G <sup>3</sup> / <sub>4</sub> " 增安型金属电缆密封套, 塑制 2 个 M25 × 1.5 空塞堵头 One brass CZ0227/M25 × 1.5-G <sup>3</sup> / <sub>4</sub> " increased safety metal cable gland, two moulded plastic M25 × 1.5 stopping plugs	Φ11-15mm
<b>G</b>	铜制 2 个 CZ0227/M25 × 1.5-G <sup>3</sup> / <sub>4</sub> " 增安型金属电缆密封套, 塑制 1 个 M25 × 1.5 空塞堵头 Two brass CZ0227/M25 × 1.5-G <sup>3</sup> / <sub>4</sub> " increased safety metal cable glands, one moulded plastic M25 × 1.5 stopping plug	Φ11-15mm
<b>H</b>	铜制 1 个 CZ0226/M25 × 1.5(G02) 增安型金属电缆密封套(填料函), 塑制 2 个 M25 × 1.5 空塞堵头 One brass CZ0226/M25 × 1.5(G02) increased safety metal cable gland (stopping boxes), two moulded plastic M25 × 1.5 stopping plugs	Φ11.5-16mm
<b>I</b>	铜制 2 个 CZ0226/M25 × 1.5(G02) 增安型金属电缆密封套(填料函), 塑制 1 个 M25 × 1.5 空塞堵头 Two brass CZ0226/M25 × 1.5(G02) increased safety metal cable glands (stopping boxes), one moulded plastic M25 × 1.5 stopping plug	Φ11.5-16mm

电缆连接回路示意图 Cable wiring diagram:

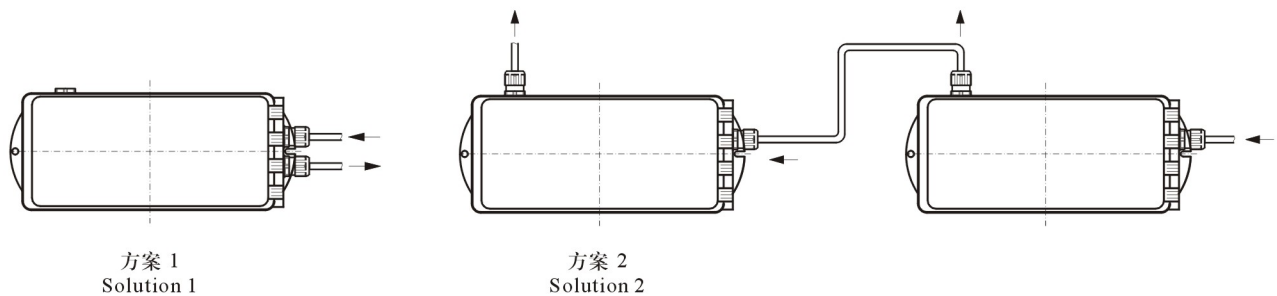

外形尺寸 Outline dimensions: 单位 Unit: mm

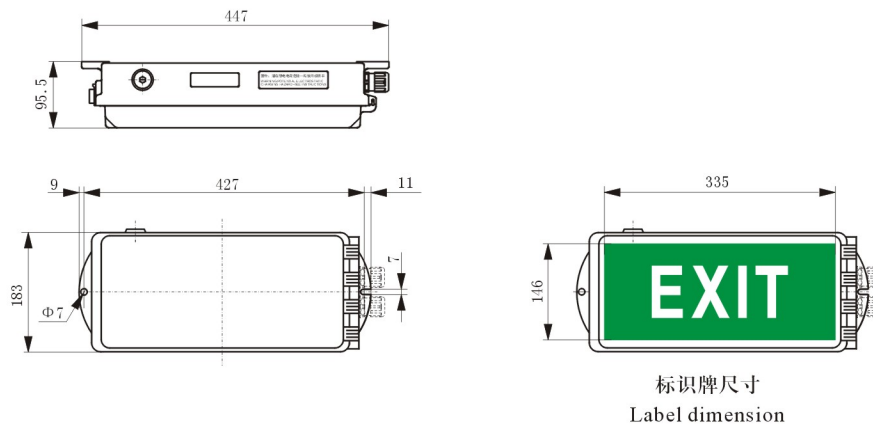

## 备件 Spare parts:

图样 Illustration	描述 Descriptions	单位 Unit	订购号 Order No.	
防爆行程开关模块 Explosion-proof isolation switch module 	防爆型式: $\text{Ex II 2G Ex db eb IIC Gb}$ 触点二常闭 (2NC) Type of protection, Contact: 2NC (2NC)	只 Piece	<b>CZ0207-1</b>	
防爆熔断器模块 Explosion-proof fuse module 	0.8A	只 Piece	<b>CZ0804 / T0.8A</b>	
	防爆型式 Type of protection $\text{Ex II 2G Ex e mb II C Gb}$	只 Piece	<b>CZ0804 / T1.25A</b>	
	1.25A	只 Piece	<b>CZ0804 / T1.25A</b>	
防爆应急电源模块 Explosion-proof emergency battery module 	防爆型式 Type of protection $\text{Ex II 2G Ex eb q IIC Gb}$ 功率: 3W Power: 3W	持续性 Maintained	只 Piece	<b>CZ0818/58-3W-M</b>
		非持续性 Non maintained	只 Piece	<b>CZ0818/58-3W-NM</b>
防爆电池模块 Explosion-proof battery module 	防爆型式 Type of protection $\text{Ex II 2G Ex eb IIC Gb}$ 电池规格: 1.0Ah/6V Battery specification: 1.0Ah/6V	套 Set	<b>CZ0819/1.0Ah/6V</b>	
接地螺母 Earthing nut 	金属接地螺母 2-M25 × 1.5 Metal earthing nut 2-M25 × 1.5	套 Set	<b>D8714/2-M25</b>	
防爆应急指示灯模块 Explosion-proof emergency indicator module 	防爆型式 Type of protection $\text{Ex II 2G Ex mb IIC Gb}$ LED三种颜色: 红、黄、绿 Three colors for LED: red, yellow, green	套 Set	<b>CZ0802/1</b>	
M8/SW13 套筒扳手 M8/SW13 Sleeve spanner 	材质: 优质钢表面镀锌 Material: Fine quality steel with galvanized surface	套 Set	<b>D601</b>	